

#### Purpose

The NTRL02 Terminal on Unit (TU) provides NR002 Remote I/O (RIO) Modules and feed equipment with a remote communication interface via a 1 Megabit/second fiber optic data link. The NTRL02 is designed for point-to-point communication and allows for a maximum cable distance between a master and slave RIO of 10,000 feet (3000 meters). This distance can be doubled by using two TUs with JP1 jumpered for repeater mode, and a remote +24 Vdc power supply. This TU also supports communication to Digital Control and Digital Indicator Station.

#### Description

The NTRL02 Terminal on Unit, as shown in Figure 1, requires +24 Vdc I/O power to drive its circuitry and has a maximum current consumption of 170 mA. A 25 Amp fuse (F1) provides input protection and a 5 Amp fuse (F2) is fused to the Digital Stations.

The following steps must be performed before the NTRL01, NTRL02, or NTRL03 Terminal on Units are put into operation.

#### Handling

##### Special Handling

The NTRL01, NTRL02, and NTRL03 TUs use Electrostatic Sensitive (ESD) devices. Follow these handling procedures:

1. Keep the TU in the special static bag until you are ready to install it in the system. Save the bag for future use.
2. Ground the anti-static bag before opening.
3. Verify that all devices connected to the TU are properly grounded before using it.
4. Avoid touching the circuitry when handling the TU.

**NOTE:** Grounding straps (feed static kiks) must be used when installing or removing the TU to configure or change jumper settings.

##### General Handling

1. Examine the TU immediately to verify that no damage has occurred in transit.

TABLE 1 NTRL02 Application Summary

INTERFACES TO	CABLE	APPLICATION
Remote I/O Module NR002	NKLM01	Provides communication between NR002s and the NTRL02.
NTRL02	Fiber Optic	Provides communication between NR002s.
Digital Control Station NDCS03	NKDS01 NKDS02	Provides communication between NR002 and NDCS03 with or without bypass or ND S01.
Control Station Terminal on Unit NTCS02	NKSE01	Provides communication between NR002s and NDCS03 with or without bypass or ND S01.

## NTRL02

2 Notify the nearest Bailey Control Services/Service Office of any damage

3 File a claim for any damage with the transportation company that handled the shipment

4 Use the original packing material and/or container to store the TU

5 Store the TU in an environment of good air quality, and free from temperature and moisture extremes

### Installation

The NTRL02 TU can mount on a Field Termination Panel with a Process Control Unit (PCU), remotely. The maximum distance between the NTRL02 and NR002 is 200 feet (60 meters). Please refer to the Termination Unit and Cable Installation section of this manual for complete installation instructions or other information as necessary.

### Cable Connection

An NKLM01 cable connects between P1 on the TU and P3 on the RO. Fiber optic cable connects two TUs via TX and RX.

Exercise caution when connecting fiber optic cables. Pay strict attention to the bend radius specification on putting tensile strength during installation and normal system operation. Termination of the fiber optic cable with SMA type connectors must be performed by qualified personnel.

### Fiber Optic Budget

The optical link has a minimum of 15 decibels (dB) of power that can be expended in a system. This is referred to as the Power Budget. The 15 dB of power that can be expended in a system. This is referred to as the Power Budget. The 15 dB of power is guaranteed when 62.5/125 micrometer fiber size is used.

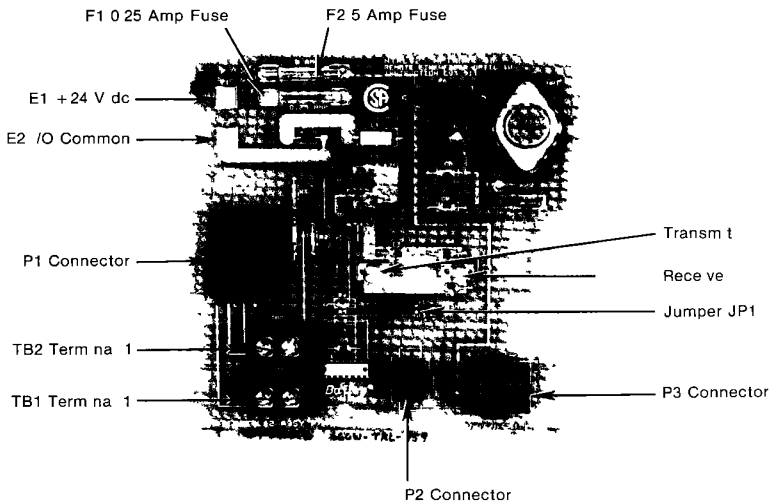

FIGURE 1 NTRL02 Termination Unit

The Power Budget determines the maximum distance over which the link can operate. The losses in a system measured in relative decibels are due to fiber losses specified in dB/km and losses due to connectors or splices in the system. The 62.5/125 fiber is available in 2 km maximum lengths with the maximum loss rates at 3.3 dB/km.

**Example**

If 3 km of cables used the insertion loss due to the fibers

$$3.3 \text{ dB/km} \times 3 \text{ km} = 9.9 \text{ dB}$$

Connector losses, if installed properly amount to an average of 1 dB per connector

If one connection is made in the cable the total loss due to connectors is 3 dB. This includes 1 dB each as the receiver and transmitter

The total loss to the system is

$$9.9 \text{ dB} + 3 \text{ dB} = 12.9 \text{ dB}$$

There would then be 2.1 dB left in the Power Budget (15 dB - 12.9 dB = 2.1 dB). This is the safety margin and should be at least 2 dB to allow for component degradation.

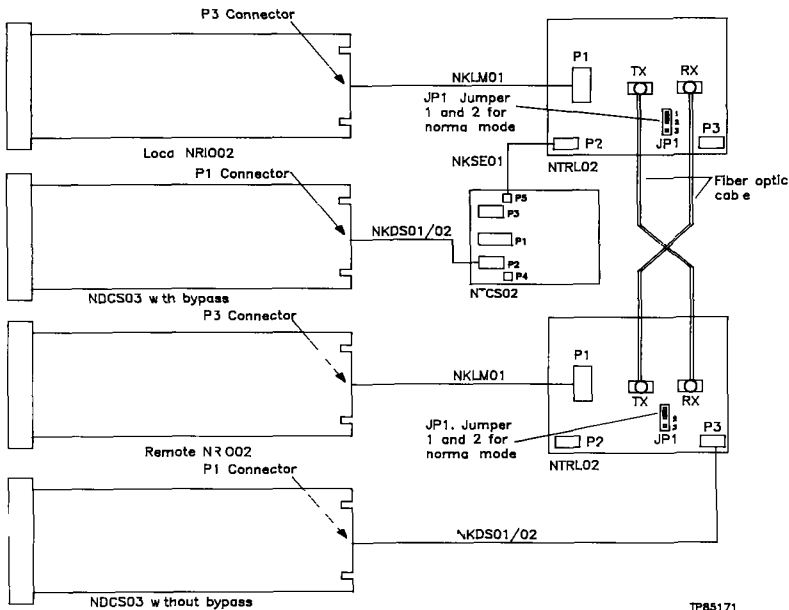
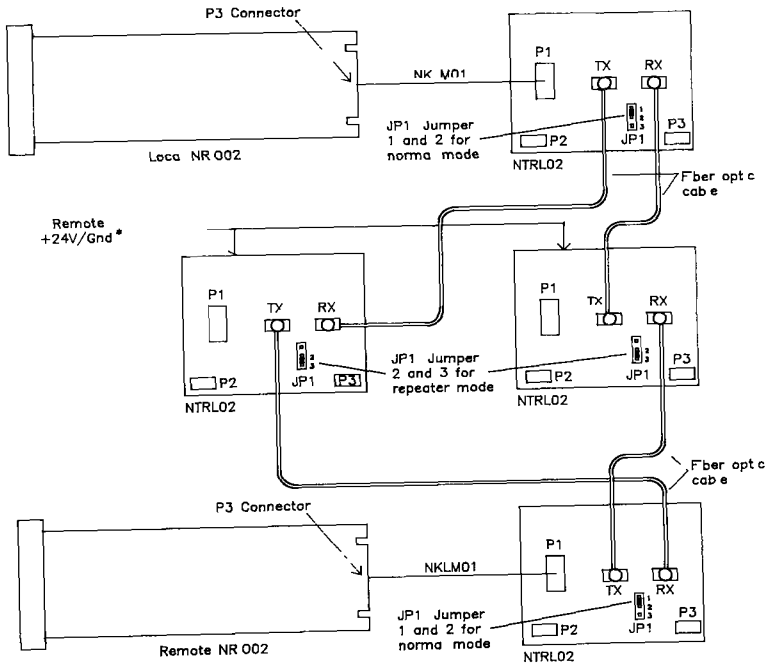

FIGURE 2 Cable Connections for NTRL02 Normal Mode

NTRL02



\* If this remote power is removed for any reason, the communication network stop operating

TP85170

FIGURE 3 Cable Connections for NTRL02 Repeater Mode